

Model	Capacity @ 600 mm LC	Fuel Type	Engine
2080H	8,000 kg	Diesel	Yuchai 6J125Z-T20 / 6.494 L
2080H	8,000 kg	Diesel	Isuzu A-6BG1QC-02 / 6.494 L

# 2080H

Diesel  
Pneumatic Tire Forklifts



**TOUGH WORLD. TOUGH EQUIPMENT.**

# 2080H Diesel • Pneumatic Tire Forklifts



General	1	Model			2080H	2080H
	2	Power Type			Diesel	Diesel
	3	Base Capacity	@ rated load center	kg	8,000	8,000
	4	Load Center		mm	600	600
Weights	5	Service Weight	unloaded	kg	11,500	11,500
	6	Axle Load	loaded / unloaded, front	kg	17,400 / 5,050	17,400 / 5,050
	7		loaded / unloaded, rear	kg	2,100 / 64,50	2,100 / 64,50
Tires	8	Tire Type			Pneumatic	Pneumatic
	9	Wheels	front / rear		4 / 2	4 / 2
	10	Wheelbase		mm	2,600	2,600
	11	Tire Size	front		9.00-20-14PR	9.00-20-14PR
	12		rear		9.00-20-14PR	9.00-20-14PR
	13	Tread Width	front / rear		1,600 / 1,720	1,600 / 1,720
Mast	14	Max. Fork Height	with std 2-stage mast	mm	3,000	3,000
	15	Freelift	with std 2-stage mast	mm	200	200
	16	Height, Upright Lowered	with std 2-stage mast	mm	2,675	2,675
	17	Height, Upright Extended	with std 2-stage mast	mm	4,175	4,175
	18	Mast Tilt, Fwd / Bwd	with std 2-stage mast	deg	6° / 12°	6° / 12°
	19	Carriage	width	mm	2,210	2,210
	20	Fork Spread	minimum / maximum	mm	430 / 2,130	430 / 2,130
	21	Fork Dimension	T x W x L	mm	70x170x1,520	70x170x1,520
Chassis	22	Length to Fork Face	with std 2-stage mast	mm	4,050	4,050
	23	Overall Width		mm	2,210	2,210
	24	Overhead Guard Height		mm	2,646	2,646
	25	Turning Radius	minimum outside	mm	3,750	3,750
	26	Fork Overhang	with std 2-stage mast	mm	710	710
	27	Right Angle Stack	add load length and clearance	mm	5,860	5,860
	28	Ground Clearance	minimum loaded	mm	290	290
	29		center of wheelbase	mm	300	300
	Performance	30	Travel Speed	loaded / unloaded	km/h	23 / 28
31		Lift Speed	loaded / unloaded	m/s	0.45 / 0.48	0.41 / 0.44
32		Lower Speed	loaded / unloaded	m/s	0.48 / 0.35	0.48 / 0.35
33		Max. Drawbar Pull	loaded	kg	6,500	6,500
34		Max. Gradeability	loaded / unloaded	%	30 / 28	30 / 28
Systems	35	Brakes	service		Foot / Hyd	Foot / Hyd
	36		parking		Hand / Mech	Hand / Mech
	37	Engine	manufacturer		Yuchai	Isuzu
	38		model		6J125Z-T20	A-6BG1QC-02
	39		emission compliance		China Tier II	Euro Tier I
	40		cylinders		6	6
	41		displacement	liter	6.494	6.494
	42		rated power	kw/rpm	92 / 2,200	82.4 / 2,000
	43		max. torque	N • m/rpm	500 / 1, 500	416.8 / 1,500

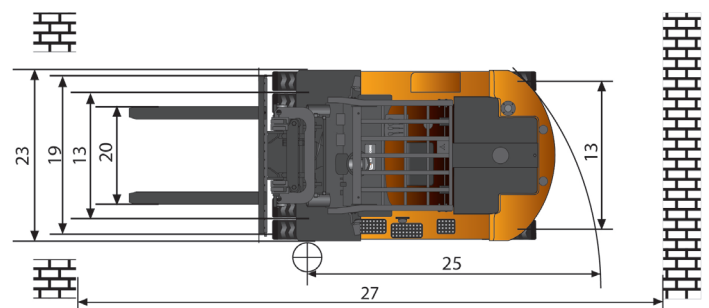
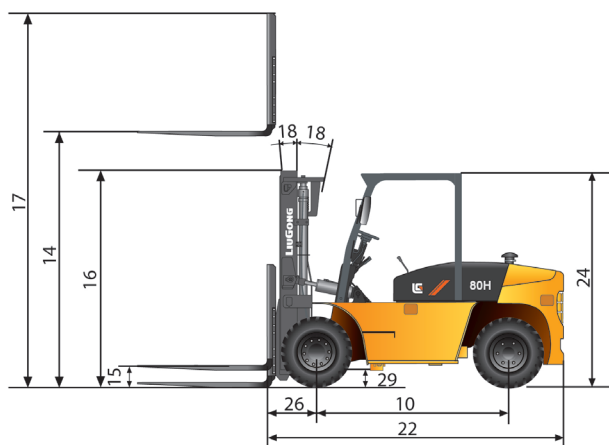

## Guangxi Liugong Machinery Co., Ltd.

No. 1 Liutai Road, Liuzhou, Guangxi 545007, PR China  
 T: +86 772 3886124 E: overseas@liugong.com  
 www.liugong.com

02/2014 Designed by LiuGong